

Instruction Manual

Premier Elite PA DP-W



Texecom
Designed to Perform

PAK200556

INS572

1 - Introduction

- For wireless connectivity, detailed programming and system set-up instructions please refer to the compatible RICOCHET™ technology enabled Premier Elite wireless expander/wireless control panel instructions.
- Featuring RICOCHET™ wireless technology the Premier Elite PA DP-W is designed for professional security installations.
- The Premier Elite PA DP-W is only compatible with Premier Elite control panels V2.08 and above.

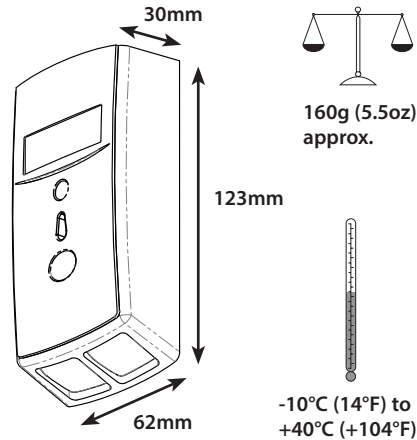

2 - Location

Do not install close to large metal objects or mains wiring.

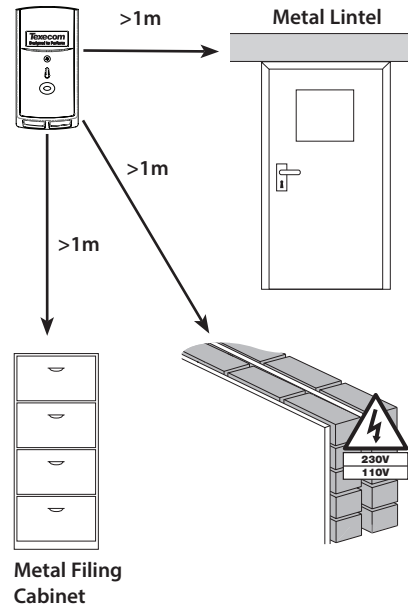

3 - Remove Cover

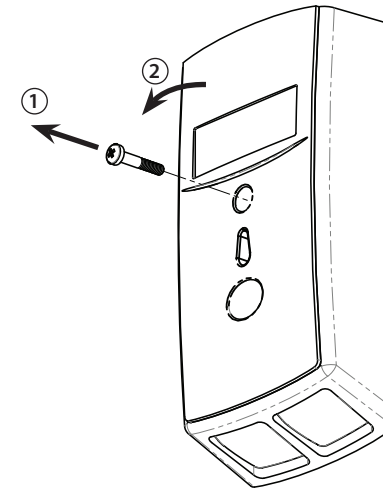

4 - Mounting Holes

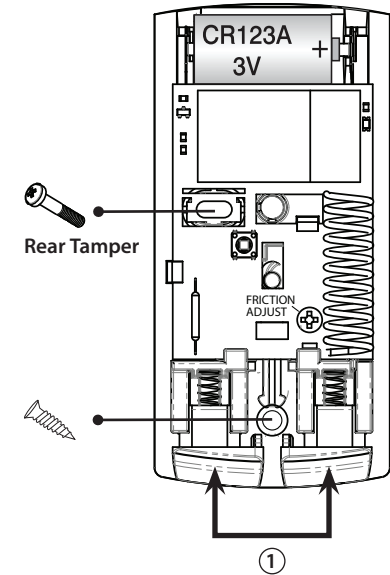

Warranty & Battery Safety

WARRANTY

2 year replacement warranty (excludes battery).

As the Premier Elite PA DP-W is not a complete alarm system, but only a part thereof, Texecom cannot accept responsibility or liability for any damages whatsoever based on a claim that the Premier Elite PA DP-W failed to function correctly.

Due to our policy of continuous improvement Texecom reserves the right to change specification without prior notice. All specifications are measured at 20°C (68°F).

BATTERY SAFETY

- Do not throw into a fire
- Do not short circuit
- Replace only with same or equivalent type(3V)
- Always observe local regulations when disposing of a battery
- Detector will transmit low battery warning when battery needs replacing
- Battery life: Up to 4 years
- Do not heat
- Do not charge
- Do not disassemble

5 - Installation

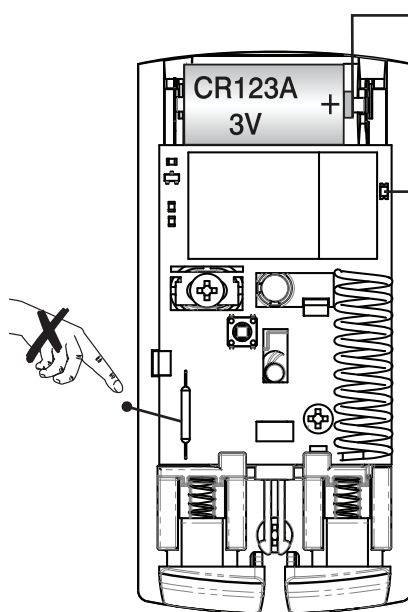

Battery Tag

DO NOT REMOVE THIS TAG UNTIL YOU ARE READY TO LEARN THE DEVICE TO THE SYSTEM.

Battery connection will automatically start the learning sequence. Device reverts back to programmed network if receiver is not in learn mode (when replacing battery).

LED

- LED Solid: Device is attempting to learn to new receiver.
- LED Flashing Rapidly: Device is attempting to connect to existing receiver.
- LED Blinking Every 0.5 Second: Device is connected to receiver.

6 - Replace Cover

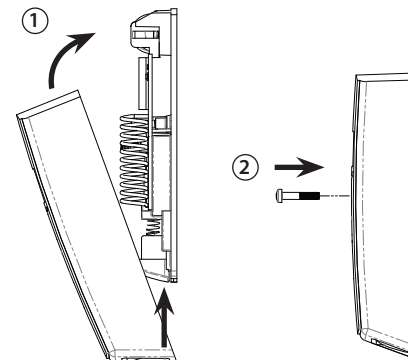

7 - Using/Resetting the PA button

- Push both buttons together to operate. After use the indicator will be red (latched).
- To reset insert the key (located inside the housing) into the slot as shown.
- Turn key clockwise as far as it will turn (about 120 degrees) to reset the PA.
- Turn the key anti-clockwise back to the start and remove it.

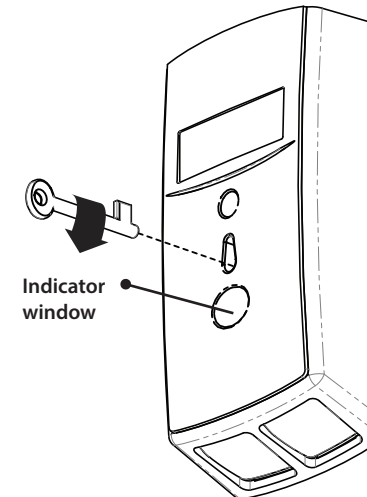

8 - Standards

Alarm Systems:	EN50131-5-3, EN50131-1, PD6662:2010, Grade 2 Class II
EMC:	EN50130-4:2011 ETSI EN301 489 V1.4.1
R&TTE:	ETSI EN300-220 (V.2.3.2)
Environmental:	EN50130-5
Frequency Band: (See product label)	868.0 - 868.6 MHz 433.05 - 434.79 MHz 866.0 - 866.6 MHz
Receiver:	Category 1, Class 2
Receiver LBT (Listen Before Talk)	Yes
Transmitter Duty Cycle	868Mhz<1%, 433Mhz<10%
Low Voltage Signal	2.85V
Operating Voltage	3V



Supplier: Texecom Ltd, St. Crispin Way, Haslingden, Lancashire, BB4 4PW, UK
Premier Elite and the Ricochet logo are trade marks of Texecom Ltd. © 2013
Contact information: www.texecom.com INS572 / PAK200556