

The JA-158P wireless outdoor PIR detector

The JA-158P is an outdoor intruder wireless detector designed to detect human body movement in a protected area. It supplements a double-zone PIR sensor produced by Optex with a Jablotron transmitter enabling the detector to be used within the JABLOTRON 100 system. The optical part of the detector has 2 PIR sensors with non-overlapping 94 zone detection, a high immunity to false alarms and the detection of small animals. The detector includes an Antimasking function – protection against covering the view and it also has two tampers (front and back) built-in. They immediately report opening the detector or attempting tampering. The detector does a self-test periodically and sends its status to the control panel. The detector should be installed by a trained technician with a valid certificate issued by an authorised distributor.

Installation

Choose a proper place for detector installation according to the following:

- The detector must be installed in a position where its bottom surface is parallel to the watched zone (either directly on the wall, or possibly, if a change of direction is required, the supplied joint can be used). This condition is essential for good immunity to false alarms. For more information see Figure 1.
- The detector should be installed 2.5 – 3 m above the ground.
- No other moving objects (bushes, trees, high grass, etc.) should be situated in the detection area of the detector. These objects can be masked out using the supplied foils. Avoid direct action by strong sources of light (sun reflections). You can use the supplied viewing hood for this purpose.
- When selecting the right place to install your detector, keep in mind that the best movement detection is provided when the detection zones intersect Figure 2.

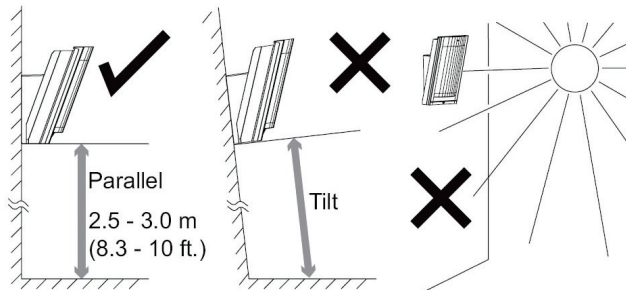

Figure 1

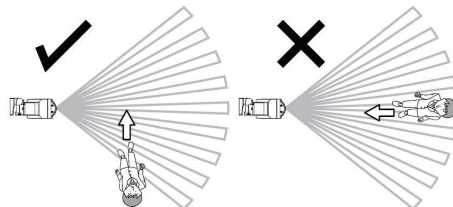

Figure 2

Procedure:

- Unfasten the securing screw on the bottom side of the upper cover and remove it.
- Pull the plastic tab under the lower PIR sensor slightly to remove the optical part. **Warning: Do not touch the detector sensing face during handling.**
- Use a screwdriver to punch a hole on the right of the bottom detector cover in order to pull the rear TAMPER cable through (supplied in the package).

When installed without the joint holder:

- Use the *Base Mounting Template* from the box lid.

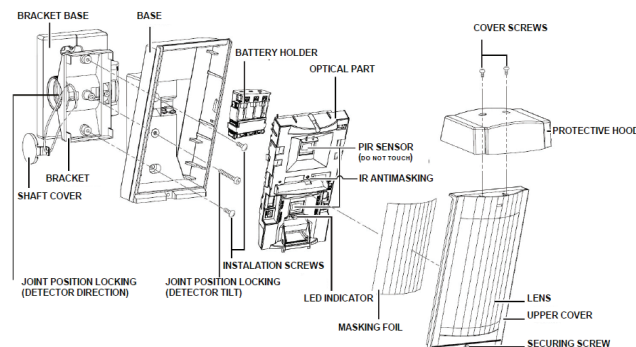

Figure 3 detector configuration

- Pull the rear TAMPER cable through the punched hole in the bottom detector cover and fix a magnetic contact to the place according to the template (*Base side*).
- Mark a place on the wall where you want to install the detector – i.e. holes for the screws and the magnet (*Wall side*), and fix the magnet to the wall.
- Fix the rear cover on the wall while checking the position of the magnet and the reed contact (they should be as close as possible).

When installed with the joint holder:

- Use the *Bracket Base Mounting Template* from the box lid.
 - Press the plastic tab to remove the screw cover (secured with a plastic cord against falling during work).
 - Unscrew the securing screw (inside under the cover) to loosen the joint and swivel it to one side to gain access to the installation holes.
 - Pull the rear TAMPER cable through the cavity in the joint and fix the magnetic contact in the given place (between plastic lugs).
 - Mark a place on the wall where you want to install the detector – i.e. holes for the screws and the magnet (*Wall side*), and fix the magnet to the wall.
 - Fix the joint holder to the wall while checking the position of the magnet and the reed contact (they must touch).
 - Now screw the bottom cover together with the joint holder. Remove the central screw which blocks vertical movement and screw it through a hole in the bottom cover.
- Pull the rear TAMPER cable through the opening you have punched in the bottom detector cover and insert the rear TAMPER connector into the pins marked EXT.TMP (3) see Figure 4 (remove the jumper installed in production).

Enrolling the detector to the system

The signal transmitter for wireless communication is located underneath the optical part of the detector. The batteries are inserted into the battery holder of the OPTEX motion detector. Use two CR123A (3 V, 1500 mAh) lithium batteries from the same manufacturer and replace both batteries at the same time. If an increased lifetime is needed, you can also use a third battery. The correct position of the batteries is indicated on the battery holder. Alternatively, LS(T) 14500 (3.6V, AA) lithium batteries can be used. When inserting the batteries, it is necessary to remove the part of the holder held in place with a metal clip.

Enrollment procedure to the system:

- There must be a JA-110R radio module installed in the control panel.
- Go to the **F-link** software, select required position in the **Devices** window and launch the enrollment mode by clicking on the **Enroll** option.
- Insert the batteries (mind the correct polarity). When the first battery has been inserted into the battery holder an enrollment signal is transmitted to the control panel and the detector is enrolled to the selected position.

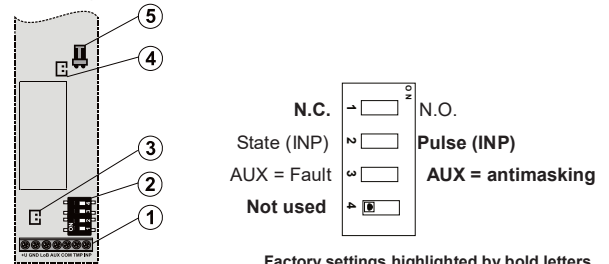

Factory settings highlighted by bold letters.

Figure 4 - Transmitter: 1 – terminals, 2 – option DIP switch, 3 – external tamper connector, 4 – external antenna jumper, 5 – external antenna connector

If needed the transmitter can be equipped with an AN-80 or AN-81 external antenna connected to the connector (5) and disconnect the jumper (4).

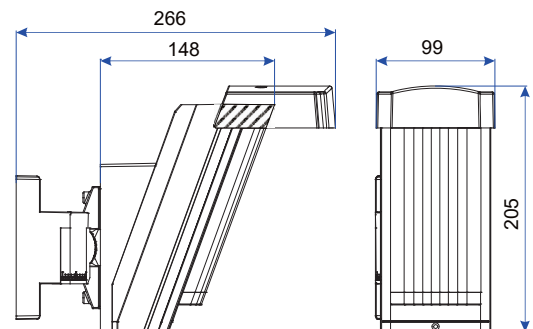
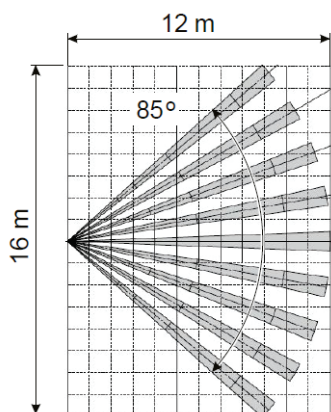
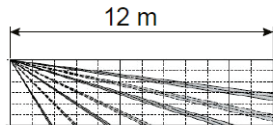

Figure 5: Detector dimensions

The JA-158P wireless outdoor PIR detector

Setting up the optical part of the PIR detector

Installation at 3.0 m above the floor



When installing the detector 2.5m above the floor, use the joint holder and swivel the detector by 2.5° (one click) upwards to achieve a 12m detection distance.

The above-mentioned detection characteristics apply if the detector is installed vertically in the guarded area. If a shorter detection range is required, do not tilt the detector on the joint. Use the supplied self-adhesive mask foils:

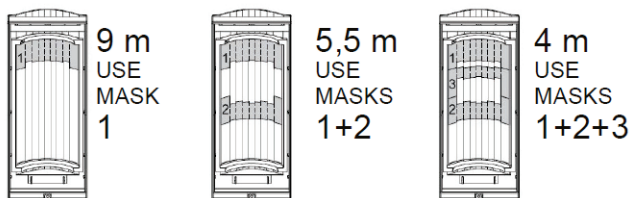

Masking using strips of the supplied foil can also be used to avoid unwanted moving objects (e.g. a tree). Use the supplied protective hood for protection against the sun and rain.

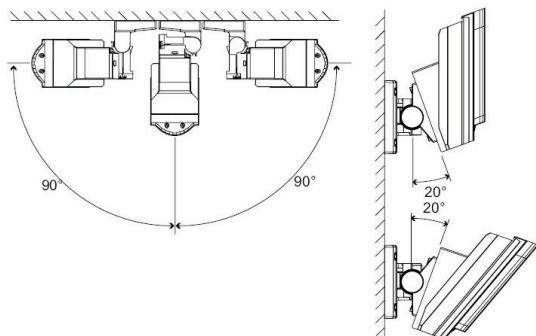

Setting up the electronic part of the PIR detector

It is possible to set three levels of detector sensitivity using the switch on the left of the bottom PIR – the levels are marked with letters:

- L** low – low sensitivity for places with false alarm risks
- M** middle – medium sensitivity
- H** high – high detection sensitivity

Other parameters can be set using the switches:

normal mode
save mode 120 s
standard immunity
Fault output N.C.
do not set this
LED disabled

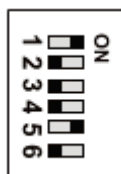

test mode
5 s
high immunity
do not set this
fault is not alarm
LED enabled

Area coverage test (DIP1) – the energy saving mode is not applied and each detectable movement is indicated by an LED. The alarm is always transmitted regardless of the energy saving mode settings (DIP2). **The energy saving mode (DIP2)**. When the detector is activated and transmits the information to the control panel, it stops detecting motion in its view for a set time. **The activation of the LED (DIP6)** serves as an indication of the detector function – i.e. the area coverage. Disable the LED to save the batteries in ordinary operation.

Testing

When the batteries are connected, the detector needs approx. 90 seconds for stabilization. The LED keeps flashing all the time. Use the DIP switch 1 to commence the area coverage test. Test the correct coverage of the guarded area and whether the detector detects motion outside the guarded area. Each movement is indicated by flashing detector LED and the information is sent to the control panel.

When the test is finished to meet the declared battery lifetime, stop the area coverage test, check whether the indication LED is off and set the energy saving mode to 120 s.

Normal operating mode

Each time the detector is activated, the information is transmitted by a radio signal. When the detector cover is opened or the detector is removed from the bearing plate, a tamper signal is transmitted. The detector also regularly (every 9 minutes) transmits control signals which serve the control panel to check the presence and readiness of all devices in the installed system.

The masking protection function

The detector has an anti-masking function – i.e. protection against masking of the detector's field of sight. If an object is detected in front of the detector for more than three minutes, the detector sends a tamper signal. Three short flashes of the LED indicate masking (the LED must be enabled). When the object has been removed, the indication (tamper signal) ceases after one minute.

It is possible to set three levels of this function using the switch on the right of the bottom PIR – the levels are marked with letters:

- HI** high – high masking detection sensitivity
- STD** standard – standard masking detection sensitivity
- OFF** off – function disabled

Factory settings pre-set to STD.

Replacing the batteries

The detector checks battery status automatically and if the batteries are running low, it informs the system that they need replacing. The detector remains fully functional. The batteries should be changed as soon as possible (within 1 week).

Before battery replacement the control panel has to be switched to service mode (see installation manual of the control panel) and then it is possible to open the cover of the panel. Always use CR123A (3 V, 1500 mAh) batteries or alternatively LS(T) 14500 (3,6 V AA) batteries.

Note: Always use 2x lithium batteries. If needed put 3x batteries in to increase the detector's lifetime.

Technical specifications

Power:	2x Lithium battery type CR123A (3.0 V / 1.4 Ah)
Average battery lifetime	2 x (3 x) CR123A, approx. 3 years (4 years)*
Alternative power	2 x Lithium battery type CR14500 (AA) 3.6 V / 2.45 Ah
Average battery lifetime	2 x (3 x) CR14500, approx. 3 years (4 years)*
	* valid for enabled 120 s saving mode
	Please note: Batteries are not included
Communication band	868.1 MHz
RF range – distance from the control panel	up to 300 m (open area)

Optex detector parameters

Detection characteristics	12 m / 85°; 94 segments
Recommended installation height	2.5 – 3.0 m
Object motion speed	0.3 – 1.5 ms ⁻¹
Battery saving timer	adjustable 5 s or 120 s
Detector cover conformance	IP55
Max. relative humidity of the environment	95%
Operational environment according to EN 50131-1	IV
Operating temperature range	-20 °C to +60 °C
Security grade	according to OPTEX
Complies with	ETSI EN 300 220, EN 50130-4, EN 55022, EN 60950-1
Weight	620 g
Can be operated according to	ERC REC 70-03



JABLOTRON ALARMS a.s. hereby declares that the JA-158P is in compliance with the essential requirements and other relevant provisions of Directive 1999/5/EC and 2011/65/EU. The original of the conformity assessment can be found at www.jablotron.com - Technical Support section. Note: Although this product does not contain any harmful materials we suggest you return the product to the dealer or directly to the producer after use. For more detailed information visit www.jablotron.com.